

Mechanical Sealing Systems

Typical applications

The SB2B is a specially designed double cartridge seal to be used with big bore and standard bore pumps in cooking, evaporation and causticising plants and toxic, environmentally hazardous, abrasive and effluent liquids. The SB2S is a special variation, tailor-made seal for special applications. A wide variety of engineered designs are available.

- Fits into big bore and standard bore backheads
- Reduced inventories
- Easy to install
- Proven technology

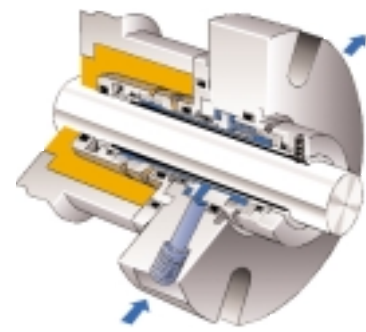

Safeseal SB2B

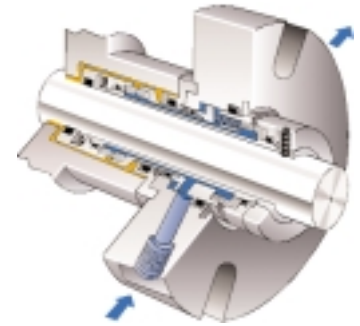

Safeseal SB2S



Heavy Duty Cartridge Seals for ANSI Pumps



SB2B, SB2S

Technical specification

Stuffing Box Pressure	290 Psi (20 bar) max
Velocity	65 ft/s (20 m/s) max
Barrier Fluid Pressure	215 Psi (15 bar) max
Temperature	350 °F (180 °C) max

Materials

Seal faces	SiC vs. SiC
	SiC vs. Carbon
O-rings	PTFE against the product
	EPDM optional
	VITON optional
Metallurgy	AISI 329 standard
	Titanium, Alloy 20,
	Hastelloy available
Springs	Nimonic steel

SB2A

Technical specifications

Stuffing Box Pressure	290 Psi (20 bar) max
Barrier Fluid Pressure	215 Psi (15 bar) max
Velocity	65 ft/s (20 m/s) max
Temperature	350 °F (180 °C) max

Materials

Seal faces	SiC vs. SiC (product side)
	SiC vs. Carbon (atm.side)
O-rings	PTFE against the product
	EPDM optional
	Viton optional, etc.
Metallurgy	AISI 329 standard
	Titanium, Alloy 20,
	Hastelloy available
Springs	Nimonic steel

Criteria for installation for all types

Shaft / Sleeve	Limits
Surface Finish	63 μ inch/1.6 μm Ra
Ovality / Out of Roundness (shaft)	0.002 inch/0.05 mm
End Play / Axial Float Allowance	±0.06 inch/±2.0 mm
Runout / Out of Squareness	±0.02 inch/±0.5 mm
Shaft Squareness to Housing	0.005 inch/0.13 mm

SB1A

Technical specifications

Stuffing Box Pressure	290 Psi (20 Bar) max
Velocity	65 ft/s (20 m/s) max
Temperature	250 °F (120 °C) max

Materials

Seal faces	SiC vs. SiC
	SiC vs. Carbon
O-rings	PTFE
	EPDM
	VITON
Metallurgy	AISI 329 standard
Springs	Nimonic steel



Asia Pacific

Singapore
Tel: 65-222-9161
Fax: 65-223-5035

Europe, Africa and Asia

Slough, UK
Tel: 44-1753-224000
Fax: 44-1753-224224

Latin America

São Paulo, Brazil
Tel: 55-11-3049-9979
Fax: 55-11-3849-4511

North America

Morton Grove, Illinois USA
Tel: 1-847-967-2400
Fax: 1-847-967-3915
1-800-SEALING

smiths

A part of Smiths Group plc

For the nearest John Crane location, please contact one of the locations above.

If the products featured will be used in a potentially dangerous and/or hazardous process, your John Crane representative should be consulted prior to their selection and use. In the interest of continuous development, John Crane Companies reserve the right to alter designs and specifications without prior notice. It is dangerous to smoke while handling products made from PTFE. Old and new PTFE products must not be incinerated.

Safeseal SB1A

Typical applications

The Safeseal SB1A is suitable for various media, e.g. water, oils, solvents and pulp (consistency up to 2%). Typical applications for this seal are pumps in paper and board mills, power plants and other process equipment.

The SB1A is a versatile seal which is easy to install and service. Although the design of the seal is simple, it contains advanced technical features like patented seal face holders and elastic thrust ring.

Features

- The balanced cartridge construction makes the Safeseal SB1A suitable for a wide range of demanding applications.
- Due to the cartridge construction the seal can be easily installed.
- The seal allows a maximum of $\pm 0.08"$ (2 mm) axial movement and 0.02" runout.
- The springs of the seal are located in the stationary housing outside of the product.
- A flush connection is incorporated for higher consistencies.

1. Balanced design

Pressure shocks do not affect seal operation.

2. Springs in the stationary part

Shaft misalignment will not pulsate the springs and wear out o-rings.

3. SiC/Carbon faces as standard

Excellent pv-rating for condensate service and high speed pumps.

4. Cartridge design

Easy installation, less human errors.

5. No drive pins

No face cracking during start-up.

6. Available in different materials

Covers all single seal applications.

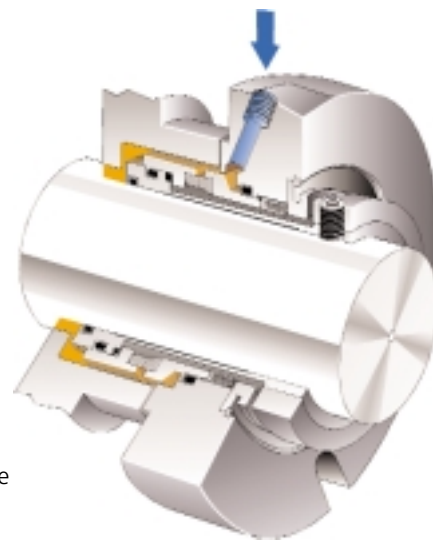

Safeunit™

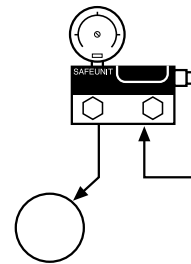

40-80 Psi (3-6 bar)
1/4-1 GPM (0.5-2.5 l/min)

Safeseal SB2A

Typical applications

The SB2A is a specially designed double cartridge seal for severe applications. Typical applications include those found in cooking, evaporation and causticising plants, toxic, environmentally hazardous, abrasive and effluent liquids. This seal can be used in major process equipment including pumps, agitators, mixers, etc.

Unique features of the SB2A

1. A patented technique is used for fastening the seal faces which assures correct face alignment. This process allows for major temperature fluctuations without face distortion.
2. Only one set of non-rotating springs are used. The springs are isolated from the product to prevent clogging and corrosion.
3. The seal has a piston design which allows it to float with the shaft during axial movement such as during an impeller adjustment.

4. A patented PTFE slot ring is used in place of a traditional o-ring where exposed to the product. The slot ring design prevents o-ring hang up and rolling.

5. The seal face carriers are driven by machined fits to prevent seal face distortion.

6. A patented double balanced design is used to allow operation with pressurised or non-pressurised barrier fluid.

7. This seal allows a maximum of $\pm 0.08"$ (2 mm) axial movement and 0.02" runout.

This is technically the most advanced seal available today. In combination with the seal water control device SAFEUNIT™, the seal is a reliable and long-lasting solution.

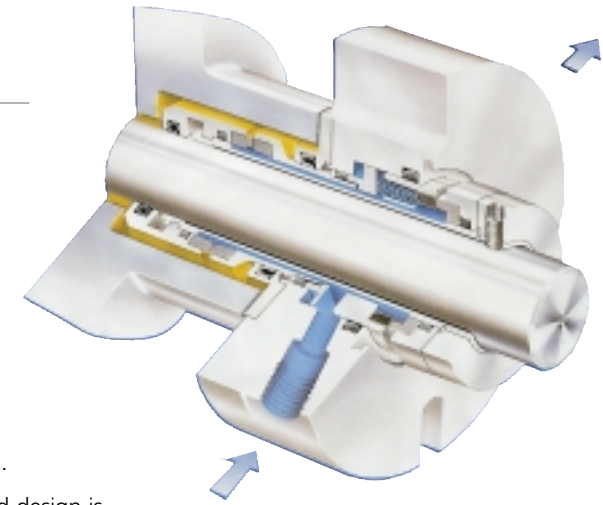

Safeunit™

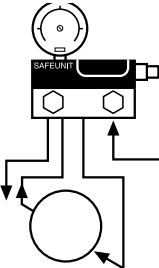

28-215 Psi (2-15 bar)
1/4-1 GPM (0.5-3 l/min)

SB1A

A Seal size	B	C min	C max	D	E	F	K	H	G J=3/8	G J=1/2
1.000	3.78	1.625	2.00	2.39	1.25	1.84	1.27	0.55	2.77	2.90
1.125	3.94	1.750	2.09	2.52	1.25	1.84	1.27	0.55	2.91	3.03
1.250	4.13	1.875	2.24	2.63	1.28	1.84	1.27	0.55	3.01	3.13
1.375	4.33	2.000	2.32	2.76	1.28	1.84	1.27	0.55	3.15	3.27
1.500	4.49	2.125	2.45	2.88	1.28	1.84	1.27	0.55	3.26	3.38
1.625	4.96	2.375	2.68	3.11	1.33	1.84	1.27	0.55	3.49	3.61
1.750	5.47	2.500	2.87	3.23	1.33	1.84	1.31	0.55	3.60	3.73
1.875	5.47	2.625	2.91	3.35	1.33	1.84	1.31	0.55	3.73	3.85
2.000	5.51	2.750	3.19	3.46	1.33	1.84	1.31	0.55	3.86	3.98
2.125	5.98	2.875	3.27	3.58	1.33	1.84	1.31	0.71	3.96	4.09
2.250	6.10	3.000	3.40	3.71	1.33	1.84	1.31	0.71	4.09	4.21
2.375	6.30	3.125	3.50	3.90	1.33	1.84	1.33	0.71	4.28	4.40
2.500	6.38	3.250	3.69	4.01	1.33	1.84	1.33	0.71	4.41	4.52
2.625	6.38	3.375	3.75	4.13	1.33	1.84	1.33	0.71	4.51	4.65
2.750	7.95	3.750	4.14	4.84	1.33	1.84	1.33	0.71	5.30	5.42
2.875	7.95	3.875	4.25	4.61	1.33	1.84	1.33	0.71	4.99	5.11
3.000	7.95	4.000	4.41	4.73	1.13	1.84	1.33	0.71	5.11	5.23
3.125	8.25	4.125	4.50	4.84	1.13	1.84	1.33	0.71	5.22	5.34
3.250	8.27	4.250	4.68	4.98	1.13	1.84	1.33	0.71	5.36	5.48
3.375	8.46	4.375	4.76	5.08	1.13	1.84	1.33	0.71	5.46	5.58
3.500	8.47	4.500	4.85	5.24	1.13	1.84	1.33	0.71	5.62	5.74
3.625	8.61	4.625	4.96	5.35	1.13	1.84	1.33	0.90	5.73	5.85
3.750	8.74	4.750	5.14	5.46	1.13	1.84	1.33	0.90	5.84	5.96
3.875	8.87	4.875	5.21	5.60	1.13	1.84	1.33	0.90	5.98	6.10
4.000	9.00	5.000	5.58	5.98	1.23	2.17	1.53	0.90	6.36	6.48
4.125	9.00	5.125	5.71	6.10	1.23	2.17	1.53	0.90	6.48	6.60
4.250	9.10	5.250	5.83	6.22	1.23	2.17	1.53	0.90	6.60	6.72
4.375	9.23	5.375	5.97	6.36	1.23	2.17	1.53	0.90	6.74	6.86
4.500	9.50	5.500	6.09	6.48	1.23	2.17	1.53	0.90	6.86	6.98
4.625	9.50	5.625	6.22	6.61	1.23	2.17	1.53	0.90	6.99	7.11
4.750	9.61	5.750	6.30	6.73	1.23	2.17	1.53	0.90	7.11	7.23
4.875	9.74	5.875	6.47	6.86	1.23	2.17	1.53	0.90	7.24	7.36
5.000	10.00	6.000	6.59	6.98	1.23	2.17	1.53	0.90	7.36	7.48

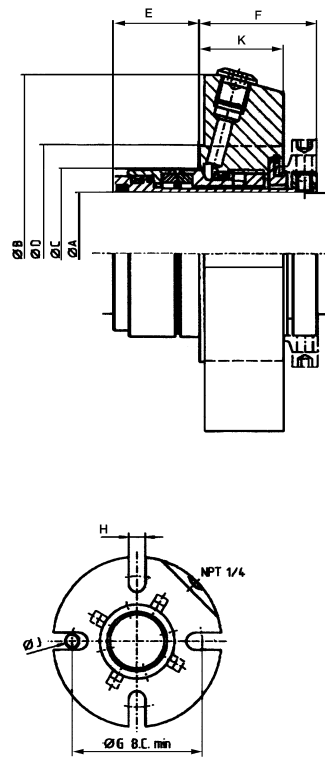

SB2A

A Seal size	B	C min	C max	D	E	F	K	H	G J=3/8	G J=1/2
1.000	3.811	1.625	1.940	2.394	1.772	2.087	1.339	0.55	2.769	2.894
1.125	3.937	1.750	2.087	2.520	1.772	2.087	1.339	0.55	2.895	3.020
1.250	4.134	1.875	2.244	2.657	1.772	2.087	1.339	0.55	3.032	3.157
1.375	4.331	2.000	2.362	2.795	1.772	2.087	1.339	0.55	3.170	3.295
1.500	4.488	2.125	2.500	2.933	1.772	2.126	1.339	0.55	3.308	3.433
1.625	4.961	2.375	2.625	3.071	1.772	2.126	1.339	0.55	3.446	3.571
1.750	5.472	2.500	2.874	3.228	1.772	2.126	1.339	0.55	3.603	3.728
1.875	5.472	2.625	2.953	3.327	1.772	2.126	1.339	0.55	3.702	3.827
2.000	5.500	2.750	3.189	3.465	1.772	2.126	1.339	0.55	3.860	3.980
2.125	5.984	2.875	3.425	3.900	1.772	2.126	1.339	0.70	4.275	4.400
2.250	5.984	3.000	3.560	4.016	1.772	2.126	1.339	0.70	4.391	4.660
2.375	6.299	3.125	3.681	4.134	1.772	2.126	1.339	0.70	4.528	4.646
2.500	6.378	3.250	3.819	4.291	1.890	2.126	1.339	0.70	4.667	4.791
2.625	6.378	3.375	3.937	4.409	1.890	2.126	1.339	0.70	4.785	4.909
2.750	7.953	3.750	4.449	4.921	2.008	2.362	1.421	0.70	5.300	5.421
2.875	7.953	3.875	4.567	5.039	2.008	2.362	1.421	0.70	5.414	5.539
3.000	7.953	4.000	4.685	5.197	2.008	2.362	1.421	0.70	5.572	5.697
3.125	8.250	4.125	4.822	5.322	2.008	2.362	1.421	0.70	5.697	5.822
3.250	8.250	4.250	4.937	5.394	2.008	2.362	1.421	0.70	5.769	5.894
3.375	8.374	4.375	5.062	5.512	2.008	2.362	1.421	0.70	5.887	6.012
3.500	8.465	4.500	5.181	5.630	2.008	2.362	1.421	0.70	6.005	6.130
3.625	8.583	4.625	5.306	5.752	2.008	2.362	1.421	0.90	6.127	6.252
3.750	8.740	4.750	5.433	5.984	2.008	2.362	1.421	0.90	6.359	6.484
3.875	8.858	4.875	5.556	6.102	2.008	2.362	1.421	0.90	6.477	6.602
4.000	9.000	5.000	5.687	6.181	2.126	2.362	1.421	0.90	6.572	6.697
4.125	9.016	5.125	5.716	6.311	2.126	2.362	1.421	0.90	6.686	6.811
4.250	9.228	5.250	5.921	6.433	2.126	2.362	1.421	0.90	6.808	6.933
4.375	9.331	5.375	6.056	6.559	2.126	2.362	1.421	0.90	6.934	7.059
4.500	9.500	5.500	6.170	6.700	2.126	2.362	1.421	0.90	7.075	7.200
4.625	9.606	5.625	6.300	6.811	2.126	2.362	1.421	0.90	7.186	7.311
4.750	9.606	5.750	6.417	6.969	2.126	2.362	1.421	0.90	7.344	7.469
4.875	9.843	5.875	6.550	7.087	2.126	2.362	1.421	0.90	7.462	7.587
5.000	10.000	6.000	6.687	7.182	2.126	2.362	1.421	0.90	7.560	7.685

