

Mechanical Sealing Systems



SE Seal Identification Codes

E.g. SE2-P1-QRMG-301169
 XXX-XX-X₁-X₂-X₃-X₄-XXXXXX

① ② ③ ④

① Type of seal
 SE1; single seal
 SEW; quench wash seal
 SE2; double seal

② Shaft diameter; (mm, in)

③ Material codes

X ₁	X ₂	X ₃	X ₄
Q-SiC/SiC	R-AISI 316/329	M-PTFE	O- single seal
G-SiC/carbon	T-titanium	E-EPDM	N-TC/carbon
T-TC/TC	U-UHB 904 L	V-Viton®	G-SiC/carbon
			V- V-ring (quench)

④ Design number
 P1= tailor made for APP-pumps with four bolts
 AP= new seal version

John Crane has a comprehensive network of highly trained representatives, distributors, and installation and maintenance personnel. Contact your local John Crane sales office for more information.

Mechanical Seals for Sulzer Ahlstar Pumps



Asia Pacific
 Singapore

Tel: 65-222-9161
 Fax: 65-223-5035

Europe, Africa and Asia
 Slough, UK

Tel: 44-1753-224000
 Fax: 44-1753-224224

Latin America
 São Paulo, Brazil

Tel: 55-11-3049-9979
 Fax: 55-11-3849-4511

North America
 Morton Grove, Illinois USA

Tel: 1-847-967-2400
 Fax: 1-847-967-3915
1-800-SEALING

smiths
 A part of Smiths Group plc

For the nearest John Crane location, please contact one of the locations above.

If the products featured will be used in a potentially dangerous and/or hazardous process, your John Crane representative should be consulted prior to their selection and use. In the interest of continuous development, John Crane Companies reserve the right to alter designs and specifications without prior notice. It is dangerous to smoke while handling products made from PTFE. Old and new PTFE products must not be incinerated.

SAFEMATIC® SE1, SEW and SE2

Safeseal SE1

Simple design, good technical solutions

Typical applications

Safeseal SE1 is a special seal designed for clean and lubricating fluids such as water, different types of oils, solvents, and stock (consistency $\leq 2\%$). It is typically used in pumps in paper and board mills as well as in power plants. The SE1 seal is designed especially for the Ahlström APP and APT pump series.

The SE1 seal is easy to install and maintain. In spite of its simple design, SE1 is very advanced in its technical capabilities, including, for example, a patented thermal method for seal face holding and an elastic thrust ring.

Features:

1. Balanced design

Undisturbed operation even with sudden pressure shocks.

2. Spring located in the stationary body of the seal

Shaft misalignment does not pump up the spring or wear out the O-ring.

3. SiC/Carbon a standard option for seal faces

SiC/Carbon holds up well under high speeds found in, for example, condensate pumps and other high temperature pumps.

4. Installation against the shaft shoulder

Easy installation reduces risk of human error. No measurements required for installation.

5. No drive pins at seals

Seal face does not crack at start-up.

6. Available in different materials

Selection covers all possible single seal applications.



Technical specifications

Stuffing box pressure max. 15 bar (215 psi)
 Speed max. 20 m/s (65 ft/s)
 Temperature max. 120 °C (250 °F)

Materials

Seal faces SiC/Carbon or SiC/SiC
 O-rings EPDM
 PTFE
 Viton®
 Metal parts Standard material AISI 329 (Titanium, UHB)
 Springs Nimonic steel

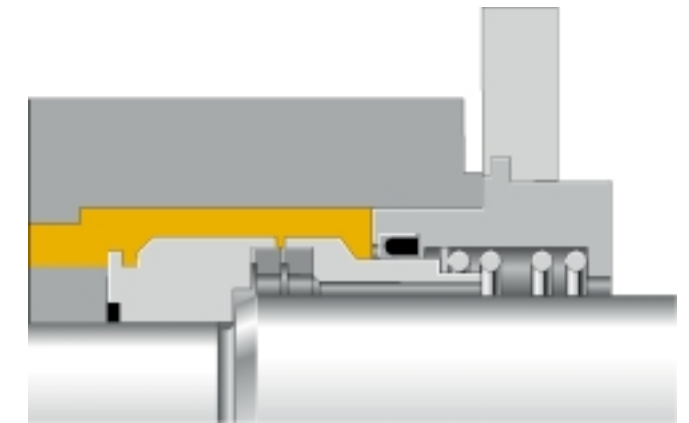

Safeseal SEW

A reliable, long-lasting seal for demanding conditions

Typical applications

SEW is a seal operating on a non-pressurised water rinsing (quench) principle, and it is designed for the most demanding applications in the pulp industry, where reliable and long-lasting operation is required from a seal. Typical applications include stock pumps at pulp mill washing and screening facilities, as well as high temperature condensate pumps. The SEW-seal is especially designed for the Ahlström APP pump series.

Features

1. Balanced design

Undisturbed operation even with sudden pressure shocks.

2. Spring located in a stationary body

Shaft misalignment does not pump up the spring or wear out the O-ring.

3. Installation against the shaft shoulder

Easy installation reduces risk of human error. No measurements required for installation.

4. No drive pins at seals

Seal face does not crack at start-up.

5. Available in different materials

Selection covers all possible single seal applications.

6. Non-pressurised seal water rinsing (quench)

Possible to cool seal with non-pressurised seal water at high temperatures. V-ring prevents water leakage from the seal.



Technical specifications

Stuffing box pressure max. 15 bar (215 psi)
 Speed max. 20 m/s (65 ft/s)
 Temperature max. 150 °C (300 °F)

Materials

Seal faces SiC/Carbon or SiC/SiC
 O-rings EPDM
 PTFE
 Viton®
 Metal parts Standard material AISI 329 (Titanium, UHB)
 Springs Nimonic steel

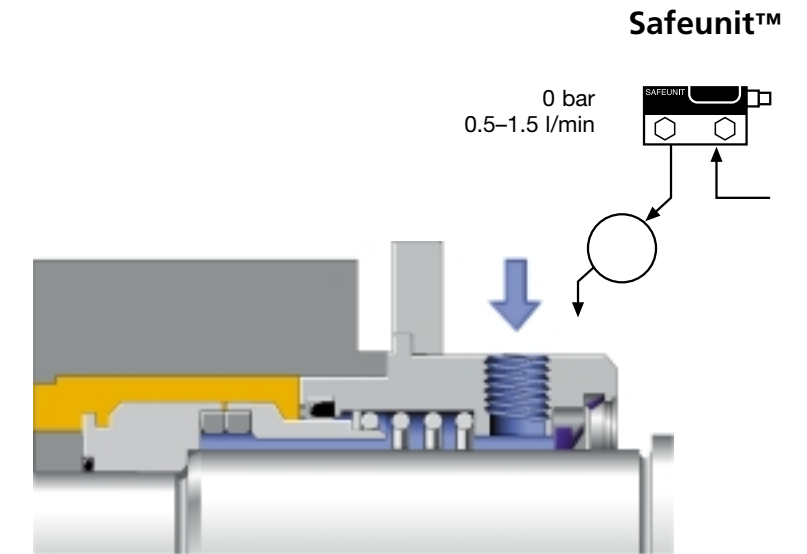

Safeseal SE2

Double-balanced design, ultimate reliability

Typical applications

The double-balanced design of Safeseal SE2 ensures reliable and long-lasting operation under the most demanding conditions. This seal is typically used in pumps for abrasive and environmentally hazardous liquids in cooking, evaporation and causticising facilities in pulp mills. The SE2 seal is especially designed for the Ahlström APP pump series.

Special features

1. Seal faces are fastened by a patented thermal heat shrink method, which ensures correct face alignment at all temperatures recommended for this seal.

2. The springs are located in the stationary body of the seal in the seal water. This allows the seal water to rinse the springs continuously, preventing corrosion by process chemicals. In addition, spring jams decrease. Shaft misalignment does not pump up springs or wear out O-rings.

3. The piston-type design of the seal enables free axial movement, therefore axial movement does not have any impact on seal face loading.

4. Even in standard models, PTFE slot rings in positions where they are exposed to the product have replaced traditional O-rings. The PTFE seal advantage is that it does not jam even in process conditions involving a lot of solid material.

5. Milled slots prevent rolling of the body ring that protects the seal face. This eliminates tension peaks that would distort the seal face.

6. The special double-balanced design allows the use of both pressurised and non-pressurised seal water.



Technical specifications

Stuffing box pressure max. 20 bar (290 psi)
 Seal water pressure max. 15 bar (215 psi)
 Speed max. 30 m/s (65 ft/s)
 Temperature max. 180 °C (350 °F)

Materials

Seal faces SiC/SiC (product side)
 SiC/Carbon (atmosphere side)
 O-rings PTFE (product side)
 Alternatives: EPDM, Viton® etc.
 Metal parts Standard material AISI 329 (Titanium, UHB)
 Springs Nimonic steel

